

Second degree surfaces in standard form

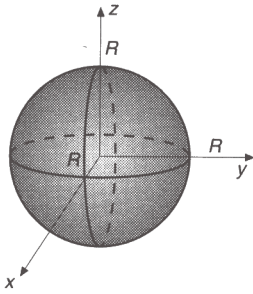

Sphere

$$x^2 + y^2 + z^2 = R^2$$

$$V = \frac{4\pi R^3}{3}$$

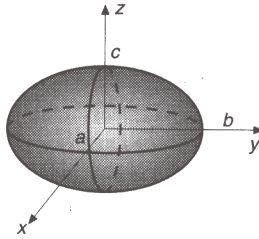

Ellipsoid

$$\frac{x^2}{a^2} + \frac{y^2}{b^2} + \frac{z^2}{c^2} = 1$$

$$V = \frac{4\pi abc}{3}$$

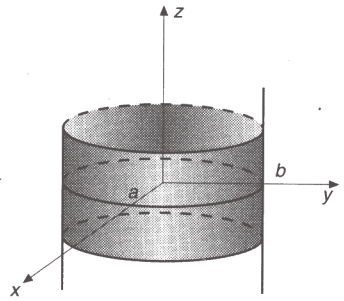

Elliptic cylinder

$$\frac{x^2}{a^2} + \frac{y^2}{b^2} = 1$$

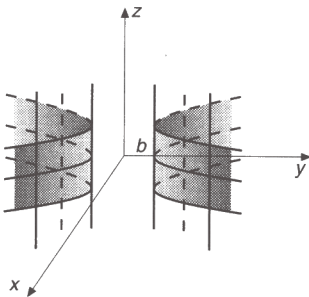

Hyperbolic Cylinder

$$\frac{x^2}{a^2} - \frac{y^2}{b^2} = -1$$

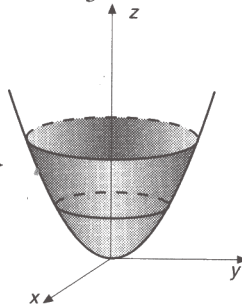

Elliptic Paraboloid

$$z = \frac{x^2}{a^2} + \frac{y^2}{b^2}$$

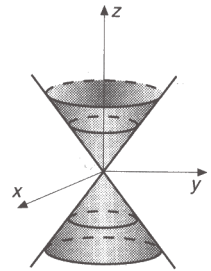

Elliptic Cone

$$\frac{x^2}{a^2} + \frac{y^2}{b^2} - \frac{z^2}{c^2} = 0$$

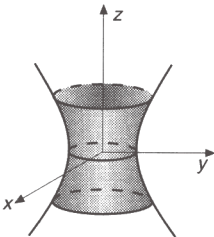

Elliptic Hyperboloid of one sheet

$$\frac{x^2}{a^2} + \frac{y^2}{b^2} - \frac{z^2}{c^2} = 1$$

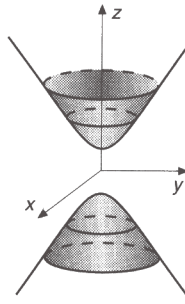

Elliptic Hyperboloid of two Sheets

$$\frac{x^2}{a^2} + \frac{y^2}{b^2} - \frac{z^2}{c^2} = -1$$

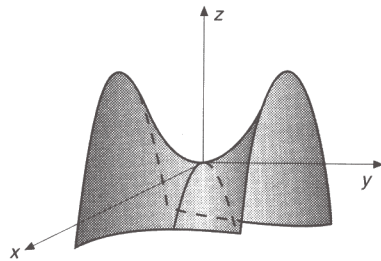

Hyperbolic Paraboloid

$$z = \frac{y^2}{b^2} - \frac{x^2}{a^2}$$